



# Industrial Mixer



A chef in a white uniform is holding a white tray. On the tray, there is a glass of red strawberry smoothie with a straw, a glass of orange juice, and a plate of fresh strawberries with green leaves. The background is a blurred white uniform.

### ...the durable mixer

The robust Kronen Industrial Mixer that was especially designed for professional use in the catering business. Unsurpassed mixing qualities make it a high-performance device for chopping foods.

Whether it's smoothies, cocktails, sauces, soups, purée or sorbets – these treats always





#SUCCESSFULLY TESTED

The new  
Kronen Industrial Mixer,  
execution, quality and  
performance guarantee  
a perfect result





turn out perfect with the Kronen Mixer and it's special knives. All components, made of top-grade stainless steel in highest quality, are manufactured in Germany or Switzerland. You have a choice of 4 table-top models with 12 programs in different executions.

## Features that will convince you

- A) A high foaming performance, as well as easy and practice-oriented operation in professional kitchens
- B) 12 different programs ensure powerful chopping with a gentle start-up
- C) An indispensable helper if you offer smoothies in your convenience area





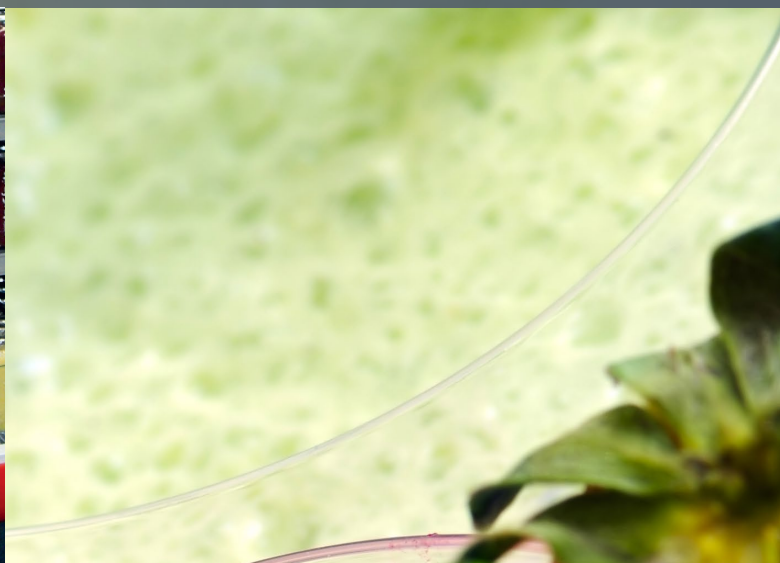

- D) Flexible and versatile operation with the various attachments in different executions
- E) Hardened stainless steel knives ensure a perfect result and long endurance
- F) Integrated into your counter as a low-noise and attractive solution in the bar- and sales-counter area



# Programm & Daten



## Execution variants

- |    |                |   |
|----|----------------|---|
| 1) | Modell KM-4 P  | 6 electronically regulated speeds, 12 programmable mix-cycles   |
| 2) | Modell KM-4 S  | with continuous speed up to 15.000 turns/Min. Thermic safety switch and electronic supervision                        |
| 3) | Modell KM-4 B  | 3 speeds (3.500, 8.700, 13.500 turns/Min.) with electronically regulated stabilization of rotation - 1 mix-attachment |
| 4) | Modell KM-4 B2 | Like Model KM-4B with 2 mix-attachments   |

## Additional technical information (all models)

Power supply	230 V / 4,2 A +/- 6 %
Maximum power consumption	900 W in continuous operation
Motor	high temperature-resistant collector motor with ventilator - gentle start-up
Electric features	Safety control for lid supervision, protection rating I, as per EN 60335-1, fitted with noise suppression as per EMV-Standard
Execution	motor base rustproof stainless steel, cutting knives made of rustproof cutlery steel
Weight	6 kg net, without attachment
Noise emission	<=70 dBA during normal operation

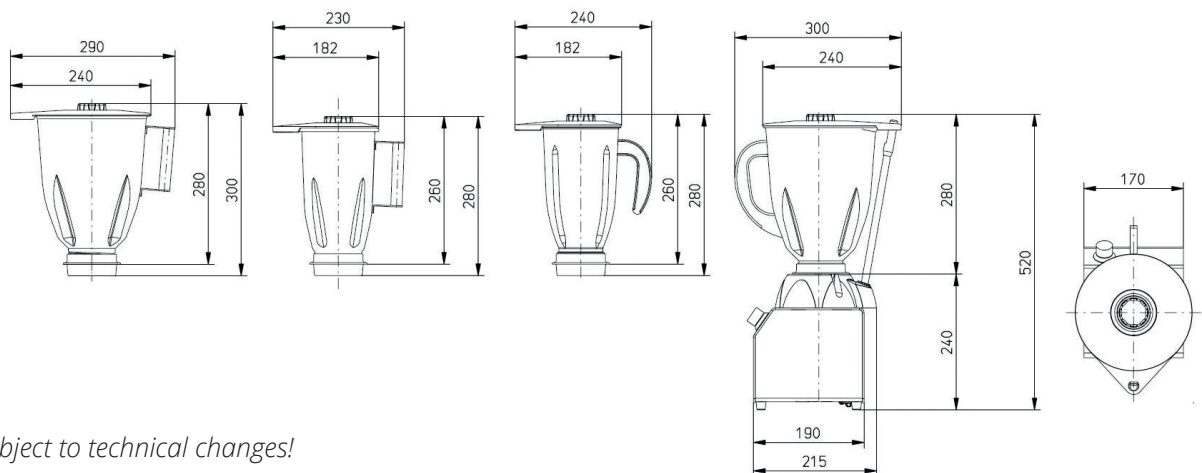

Subject to technical changes!